

---

在使用机器之前请阅读本零件手册。  
请将本零件手册放在便于查阅的地方保管。  
Please read this parts book before using the machine.  
Please keep this parts book within easy reach for quick reference.

---

## 799-FTL 左刀电脑筒式绷缝机

### 799-FTL Left-knife Computerized Tubular Coverstitch Machine

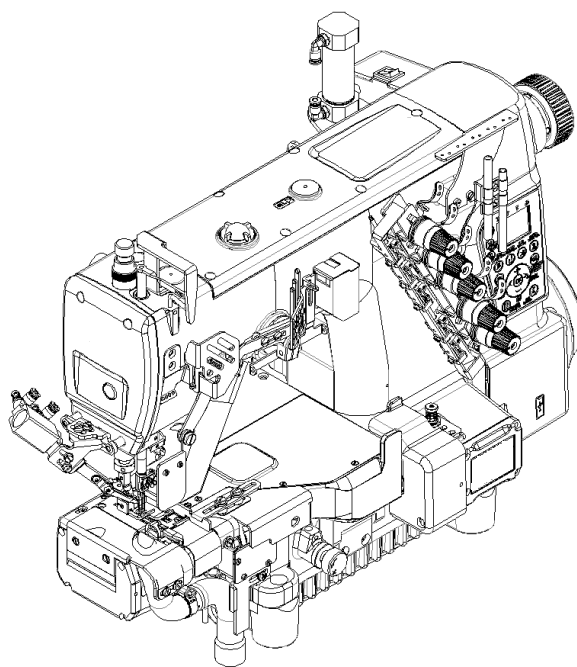

# 为了您的安全使用

## [1] 安全使用的标记及其意义

本使用说明书及产品所使用的标记和图案记号是为了您的安全而正确地使用产品，防止您及其他人受到伤害和损害。

表示方法及含意如下。

### 标记



**危险** 如果忽视此标记进行了错误的操作，肯定会引起人员死亡或重伤。



**注意** 如果忽视此标记而进行了错误的操作，有可能会引起人员受伤及造成设备损坏。

### 图案和符号



.....该符号 (△) 表示“应注意事项”。

三角中的图案表示必须要注意的实质内容。

(例如，左边的图案表示“当心受伤”)



.....该符号 (⊘) 表示“禁止”。



.....该符号 (●) 表示“必须”。

圆圈中的图案表示必须要做的事情的实质内容。

(例如，左边的图案表示“必须接地”。)

## SAFETY INSTRUCTIONS

### [1] Safety indications and their meanings

This instruction manual and the indications and symbols that are used on the machine itself are provided in order to ensure safe operation of this machine and to prevent accidents and injury to yourself or other people.

The meanings of these indications and symbols are given below.

#### Indications



**DANGER**

The instructions which follow this term indicate situations where failure to follow the instructions will result in death or serious injury.



**CAUTION**

The instructions which follow this term indicate situations where failure to follow the instructions could cause injury when using the machine or physical damage to equipment and surroundings.

#### Symbols



..... This symbol (△) indicates something that you should be careful of. The picture inside the triangle indicates the nature of the caution that must be taken.  
(For example, the symbol at left means “beware of injury”.)



..... This symbol (⊘) indicates something that you must not do.



..... This symbol (●) indicates something that you must do. The picture inside the circle indicates the nature of the thing that must be done.  
(For example, the symbol at left means “you must make the ground connection”.)

## [2] 安全注意事项

### 危险



打开控制箱盖时，先关闭电源开关并将电源插头从插座上拔下后，至少等待 5 分钟后，再打开控制箱盖。触摸带有高电压的区域将会造成人员受伤。

### 注意

#### 使用环境



应避免在强电气干扰源（如高频焊机）的附近使用本机器。

强电气干扰源可能会影响机器的正确操作。



缝纫机可以在电源电压的波动范围小于额定电压 $\pm 10\%$  以内的环境下使用。

电压大幅度的波动会影响机器的正确操作。



电源容量应大于机器的消耗电量。电源容量不足会影响机器的正确操作。



压缩空气的供气量应大于机器所要求的总耗气量。压缩空气的供气量不足可能会导致机器的操作不正常。



环境温度应在 $5^{\circ}\text{C}\sim 35^{\circ}\text{C}$ 的范围内使用。低温或高温会影响机器的正确操作。



相对湿度应在 $35\%\sim 85\%$ 的范围内，并且设备内不会形成结露的环境下使用。干燥或多湿的环境和结露会影响机器的正确操作。



万一发生雷电风暴时，关闭电源开关，并将电源插头从插座上拔下。雷电可能会影响机器的正确操作。

#### 安 装



请让受过培训的技术人员来安装机器。



请委托购买商店或电气专业人员进行电气配线。

机器质量约为55KG。



搬运缝纫机机头的搬运一定要两个人以上进行，搬运缝纫机机头时，请采取充分的安全措施，避免发生跌倒、坠落等情况，缝纫机和手上沾了油的话，很容易滑掉，有掉落的风险，所以请经常把油擦掉。

安装完成前，请不要连接电源。



如果误踩了脚踏开关，机器动作会导致受伤。



机器倒下或竖起时，请用双手进行操作。另外在机器倒下的状态下，请不要用力压机器。如机器失去平衡，机器滑落到地上是造成受伤或机器损坏的原因



必须接地。

接驳地线不牢固，是造成触电或误动作的原因。



所有电缆应固定在离活动部件至少 25mm 以外。



另外，不要过度弯曲电缆或用卡钉固定得过紧。会引起火灾或触电的危险。



如果使用带小脚轮的工作台，则应该固定小脚轮，使其不能移动。考虑操作者姿势的前提下，决定台板的高度，如果工作台过高一旦失去平衡机器倒下，会造成受伤或机器损坏。



使用润滑油及黄油时，务必戴好保护眼镜和保护手套等，以防润滑油及黄油落入眼中或沾在皮肤上，这是引起发炎的原因。



另外，润滑油及黄油不能饮用，否则会引起呕吐和腹泻。

将油放在儿童拿不到的地方。

## [2] Notes on safety

### DANGER



Wait at least 5 minutes after turning off the power switch and disconnecting the power cord from the wall outlet before opening the cover of the control box. Touching areas where high voltages are present can result in severe injury.

### CAUTION

#### Environmental requirements



Use the sewing machine in an area which is free from sources of strong electrical noise such as electrical line noise or static electric noise. Sources of strong electrical noise may cause problems with correct operation.



Any fluctuations in the power supply voltage should be within  $\pm 10\%$  of the rated voltage for the machine. Voltage fluctuations which are greater than this may cause problems with correct operation.



The power supply capacity should be greater than the requirements for the sewing machine's power consumption. Insufficient power supply capacity may cause problems with correct operation.



The pneumatic delivery capability should be greater than the requirements for the sewing machine's total air consumption. Insufficient pneumatic delivery capability may cause problems with correct operation.



The ambient temperature should be within the range of 5°C to 35°C during use. Temperatures which are lower or higher than this may cause problems with correct operation.



The relative humidity should be within the range of 45% to 85% during use, and no dew formation should occur in any devices. Excessively dry or humid environments and dew formation may cause problems with correct operation.



In the event of an electrical storm, turn off the power and disconnect the power cord from the wall outlet. Lightning may cause problems with correct operation.

#### Installation



Machine installation should only be carried out by a qualified technician.



Contact your Brother dealer or a qualified electrician for any electrical work that may need to be done.



The sewing machine weighs approximately 55 kg. The handling of the sewing machine head must be carried out by more than two people. When handling the sewing machine head, grasp the handwheel with the right hand, and put the left hand in the machine head, and lift it stably and firmly. If you try to lift the machine head yourself, it may cause injuries such as back injury.



Do not connect the power cord until installation is complete. If the foot switch is depressed by mistake, the sewing machine might start operating and injury could result.



Hold the machine head with both hands when tilting it back or returning it to its original position. In addition, do not subject the machine head to extra force while it is tilted back. If this is not observed, the machine head may become unbalanced and fall down, and serious injury or damage to the sewing machine may result.



Be sure to connect the ground. If the ground connection is not secure, you run a high risk of receiving a serious electric shock, and problems with correct operation may also occur.



All cords should be secured at least 25 mm away from any moving parts. Furthermore, do not excessively bend the cords or secure them too firmly with staples, otherwise there is the danger that fire or electric shocks could occur.



Install the safety covers to the machine head and motor.



If using a work table which has casters, the casters should be secured in such a way so that they cannot move.



If the table is too high, the machine head may become unbalanced and fall down, and serious injury or damage to the sewing machine may result.



Be sure to wear protective goggles and gloves when handling the lubricating oil and grease, so that they do not get into your eyes or onto your skin. If the oil and grease get into your eyes or onto your skin, inflammation can result. Furthermore, do not drink or eat the lubricating oil or grease. They may cause diarrhea or vomiting. Keep the oil out of the reach of children.

## 注意

### 缝 勿



本机器仅限于接受过安全操作培训的人员使用。



本机器不能用于除本身用途外的任何其他用途。



使用机器时必须带上保护镜。

如果不戴保护眼镜，断针时就会有危险，机针的折断部分可能会弹入眼镜并造成伤害。



发生下列情况时，请切断电源。

否则误按开关时，机器动作会导致受伤。

- 机针穿线时
- 更换机针时
- 机器不使用，或人离开机器时



如果使用带脚轮的工作台，则应该固定脚轮，使其不能移动。



为了安全起见，在使用本机器之前，请安装保护装置。



如果未安装这些安全装置就使用机器，会造成人身伤害及机器损坏。



运行过程中，不要触摸任何运动部件或将物件靠在运动部件上，因为这会导致人员受伤或机器损坏。



如果机器操作中发生误动作，或听到异常的噪音或闻到异常的气味，应立即切断电源。然后请与技术人员联系。



如果机器出现故障，请与售后的技术人员联系。

### 清 洁



清洁前请关闭电源开关。

否则如果误按了开关，机器动作会导致受伤



使用润滑油及黄油时，务必戴好保护眼镜和保护手套等，以防润滑油及黄油落入眼中或沾在皮肤上，这是引起发炎的原因。

另外，润滑油及黄油不能饮用，否则会引起呕吐和腹泻。

将油放在儿童拿不到的地方。

### 维 护 和 检 查



有经过训练的技术人员才能进行机器的维护、保养和检查。



与电气有关的维修、保养和检查请委托购买的商店或电气专业人员进行。



发生下列情况时，请关闭电源。并拔下电源线插座。

否则误按开关时，机器动作会导致受伤。

- 检查、调整和维修
- 更换弯针等易损零部件



在检查、调整和修理任何使用气动装备之前，请先断开气源，并等压力表指针下降到“0”为止。”



在必须接上电源开关和气源开关进行调整时，务必十分小心遵守所有的安全注意事项。



请使用该公司指定的更换零部件。











取下的安全保护装置，必须要安装回去，且请务必安装在原位上，并检查能否正常的发挥作用。





未经授权而对机器进行改装而引起的机器损坏不在保修范围内。

## CAUTION









### Sewing

-  This sewing machine should only be used by operators who have received the necessary training in safe use beforehand.
-  The sewing machine should not be used for any applications other than sewing.
-  Be sure to wear protective goggles when using the machine.  
If goggles are not worn, there is the danger that if a needle breaks, parts of the broken needle may enter your eyes and injury may result.
-  Turn off the power switch at the following times. If the foot switch is depressed by mistake, the sewing machine might start operating and injury could result.
  - When threading the needle
  - When replacing the needle
  - When not using the machine and when leaving the machine unattended
-  If using a work table which has casters, the casters should be secured in such a way so that they cannot move.
-  Attach all safety devices before using the sewing machine. If the machine is used without these devices attached, injury may result.
-  Do not touch any of the moving parts or press any objects against the machine while sewing, as this may result in personal injury or damage to the machine.
-  If an error occurs in machine operation, or if abnormal noises or smells are noticed, immediately turn off the power switch. Then contact your nearest Brother dealer or a qualified technician.
-  If the machine develops a problem, contact your nearest Brother dealer or a qualified technician.

### Cleaning

-  Turn off the power switch before carrying out cleaning. If the foot switch is depressed by mistake, the sewing machine might start operating and injury could result.
-  Be sure to wear protective goggles and gloves when handling the lubricating oil and grease, so that they do not get into your eyes or onto your skin. If the oil and grease get into your eyes or onto your skin, inflammation can result.  
Furthermore, do not drink or eat the lubricating oil or grease. They may cause diarrhea or vomiting.  
Keep the oil out of the reach of children.

### Maintenance and inspection

-  Maintenance and inspection of the sewing machine should only be carried out by a qualified technician.
-  Ask your Brother dealer or a qualified electrician to carry out any maintenance and inspection of the electrical system.
-  Turn off the power switch and disconnect the power cord before carrying out the following operations. If the foot switch is depressed by mistake, the sewing machine might start operating and injury could result.
  - Inspection, adjustment and maintenance
  - Replacing consumable parts such as the looper.
-  Disconnect the air hoses from the air supply and wait for the needle on the pressure gauge to drop to "0" before carrying out inspection, adjustment and repair of any parts which use the pneumatic equipment.
-  Hold the machine head with both hands when tilting it back or returning it to its original position.  
In addition, do not subject the machine head to extra force while it is tilted back. If this is not observed, the machine head may become unbalanced and fall down, and serious injury or damage to the sewing machine may result.
-  If the power switch and air need to be left on when carrying out some adjustment, be extremely careful to observe all safety precautions.
-  Use only the proper replacement parts as specified.
-  If any safety devices have been removed, be absolutely sure to re-install them to their original positions and check that they operate correctly before using the machine.
-  Any problems in machine operation which result from unauthorized modifications to the machine will not be covered by the warranty.



## 注意/Caution

在进行操作之前，请务必关闭电机电源并检查电机是否停止旋转。

Before performing any operations, always turn off the motor power supply and verify the motor has completely stopped rotating.

### 1. 润滑油的注入

在润滑油没有用完之前，请在固定座上的润滑油注油口①、②（两处）内注入润滑油。

#### 1.Lubrication Oil Refilling Before the

lubricant is fully depleted, inject lubricating oil into both oil filler ports ① and ② (two locations) on the fixed base.

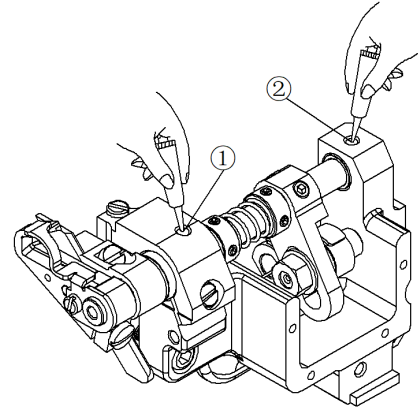

### 2. 固定刀位置的调节

松开活动刀座上的螺丝①，固定座上的螺丝②。下刀座③可以左右移动，移到合适位置后，再锁紧固定座上的螺丝②及活动刀座上的螺丝①。

#### 2.Fixed Knife Position Adjustment

Loosen screw ① on the moving knife holder and screw ② on the fixed base, then laterally adjust the lower knife holder ③ to the desired position, Tighten screw ② on the fixed base and screw ① on the moving knife holder.

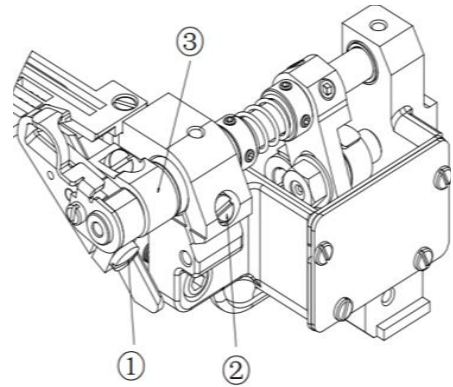

### 3. 活动刀上下行程调整

松开螺丝①，取下护盖垫片②和防油垫片③。用扳手稍微松开螺母④，调整插销轴⑤使之上下移动，往上行程越大，往下行程越小。

#### 3.Moving Knife Up Stroke Adjustment

Loosen screw ①, remove guard washer ② and oil-proof washer ③, then slightly loosen nut ④ with a wrench, Adjust pin shaft ⑤ to enable vertical movement, upward movement increases stroke, while downward movement decreases it.

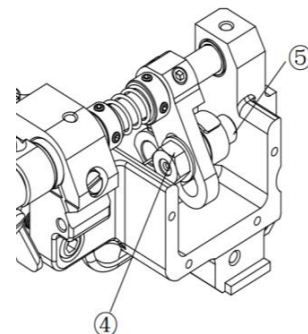
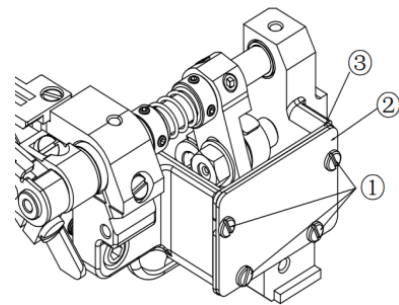

#### 4. 活动刀标准位置调整

旋转手轮使活动刀②行至下死点，松开螺丝①，调整活动刀②刀尖与固定刀③约0.5~0.8mm间距，再将螺丝①锁紧。

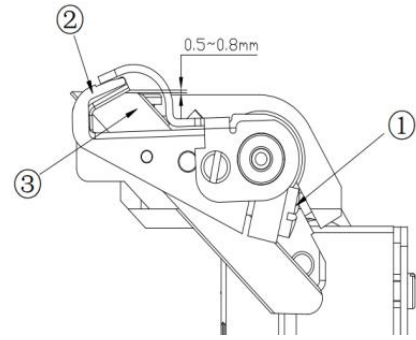

#### 4.Moving Knife Standard Position Adjustment

Rotate the handwheel to move the moving knife ② to the bottom dead center, then loosen screw ①.Adjust the moving knife ② to maintain a 0.5-0.8mm gap between its blade tip and the fixed knife ③, then tighten screw ①.

#### 5. 固定刀拆卸和安装

拆卸时，先松开挡圈①上的两个螺丝②，推动活动刀，使活动刀③和固定刀④不接触；松开螺丝⑥，再将固定刀④往下拆卸。

安装时，将固定刀④的刀尖与针板上表面对齐，拧紧固定螺丝⑤。松开挡圈①的两个止动螺丝②，弹簧力使固定刀④和活动刀③接触，并在固定刀④和活动刀③之间放线，用手旋转手轮，确认刀片的锋利度。拧紧两个固定螺丝②，再次确认刀片的锋利度。

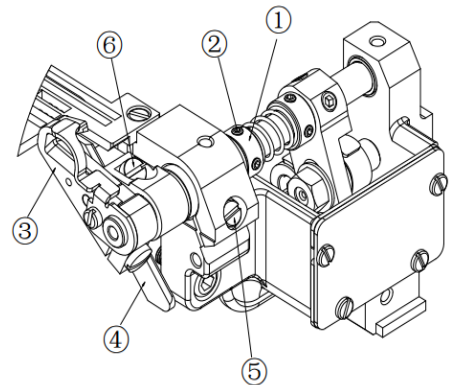

#### 5.Fixed Knife Removal and Installation

Loosen two screws ② on the retaining ring ①,Push the moving knife ③ to disengage it from the fixed knife ④;thenloosen screw⑥,then remove the fixed knife ④downward.

Align the blade tip of fixed knife ④ with the needle plate surface and tighten fixing screw ⑤.Loosen two locking screws② on retaining ring ①,allowing spring force to bring fixed knife ④ into contact with moving knife ③,Place thread between fixed knife ④ and moving knife ③, then rotate handwheel manually to verify blade sharpness.Tighten both fixing screws ② and reconfirm blade sharpness.

## 6. 固定刀之修磨

当刀片的锋利度变钝时，需拆下来修磨，修磨时需以冷水冷却。

### 6.Fixed Knife Sharpening

When blade sharpness deteriorates, remove the knife for sharpening. Always use cold water for cooling during the sharpening process.

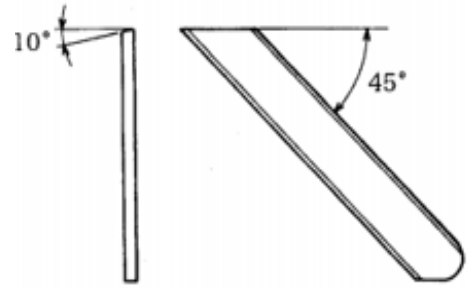

## 7. 吸入管道的调节

将吸入管①的左右位置调整到和切屑接收器④的左端面较近位置，以活动刀上下活动和切屑接收器④不干涉为原则。如果要调整或拆卸吸入管①的位置，请松开固定螺丝②。松开卡箍上的螺丝③，吸入管可旋转取出或进行吸入管①管内的清理。

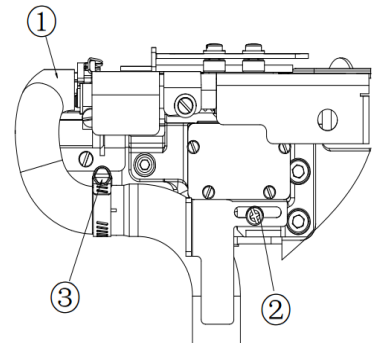

### 7.Suction Pipe Adjustment

Adjust the horizontal position of suction pipe ① to align close to the left end surface of chip receiver ④, ensuring no occurrence of interference with the vertical movement of the moving knife. To adjust or remove suction pipe ①, loosen fixing screw ②. Loosen screw ③ on the clamp to rotate and remove suction pipe ① for internal cleaning.

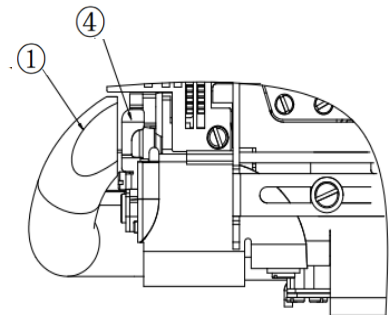

## 8. 吸入管道盖的调节

如果吸入管③的位置发生变化，请松开吸入管盖①的两个固定螺丝②；将吸入管盖①的右侧表面与吸入管③的吸入口对齐，再拧紧固定两个螺丝②。

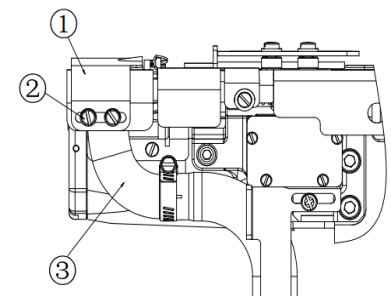

### 8.Suction Pipe Cover Adjustment

If the position of suction pipe ③ is modified, loosen the two fixing screws ② on suction pipe cover ①; Align the right-side surface of suction pipe cover ① with the suction inlet of pipe ③, then tighten and secure both fixing screws ②.

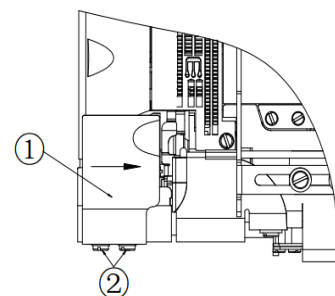

1. 左刀部件 (1) /Left-Knife Assembly (1)

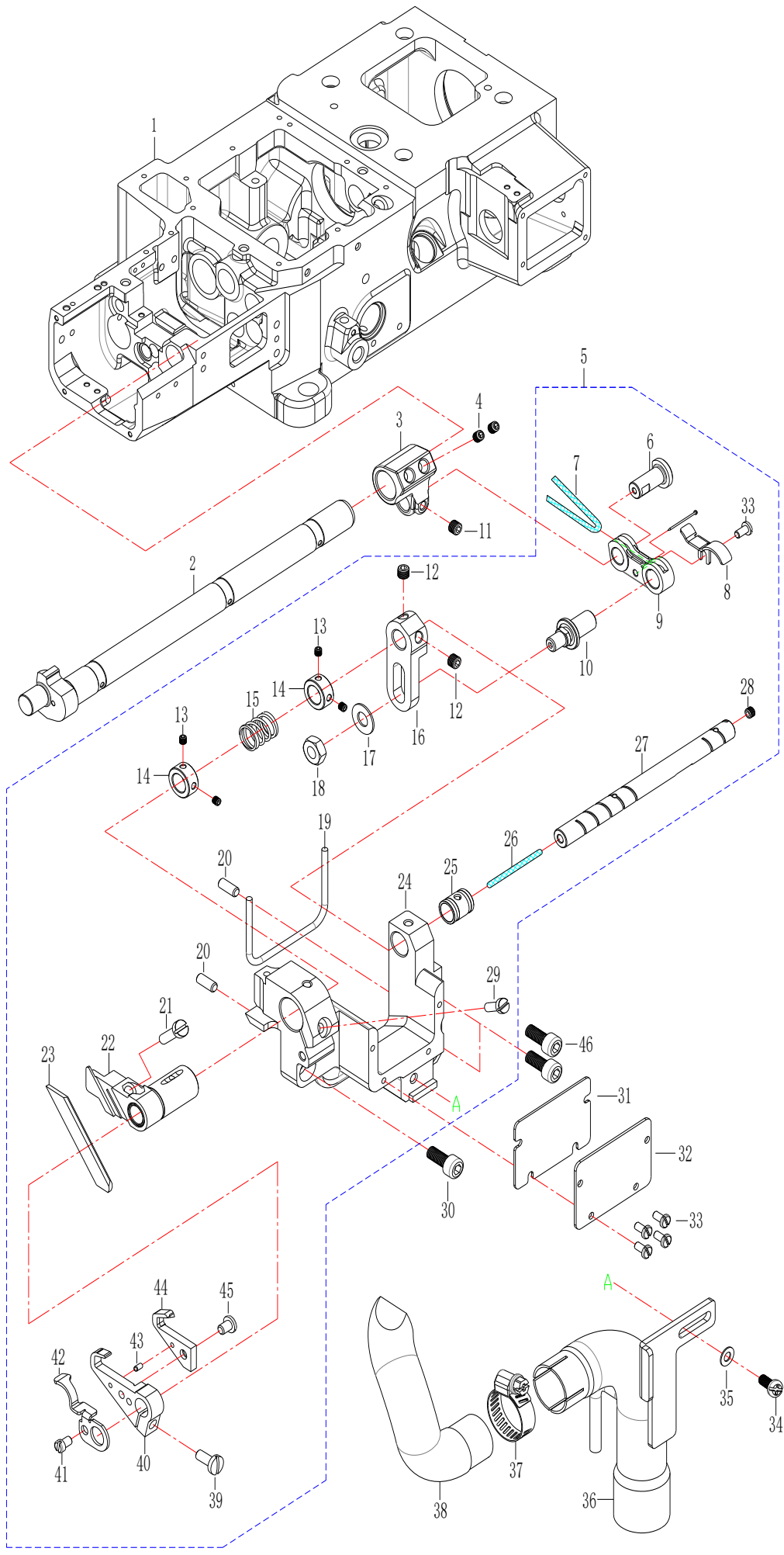

1. 左刀部件 (1) / 1. Left-Knife Assembly (1)

NO	零部件号	零部件名称	NAME OF PARTS	数量 (Number)
1	5261L010	下座	Lower base	1
2	5261V540	提升轴	Lifting shaft	1
3	5261L340	上切刀传动杆	Upper cutter drive rod	1
4	00806050	内紧定螺钉M6X5	Inner set screw M6x5	2
5	5261LZ530	左刀组件	Left knife assembly	1
6	5261L170	连杆插销	Connecting rod pin	1
7	5261W800	油线	Oil wick	0.22M
8	5261L420	压线板	Thread press plate	1
9	5261L090	上刀驱动连杆	Upper knife drive link	1
10	5261L080	可调式插销	Adjustable pin	1
11	00804040	内紧定螺钉M4X4	Inner set screw M4x4	1
12	00805041	内紧定螺钉 (黑色) M5X4	Inner set screw (black) M5x4	2
13	52093103	内六角平端紧定螺钉M3X3	Hex socket flat point set screw M3x3	4
14	5261L160	挡圈	Retaining ring	2
15	5261L140	弹簧	Spring	1
16	5261L070	上刀调整杆	Upper knife adjustment rod	1
17	00506050	平垫圈M6(发黑)	Flat washer M6 (blackened)	1
18	52035290	六角螺母M6X5	Hex nut M6x5	1
19	5261W780	油封	Oil seal	1
20	5261Q870	圆柱销Φ4x10	Dowel pin Φ4x10	2
21	52094914	一字平头螺钉M4x14 (发黑)	Flat head slotted screw M4x14 (blackened)	1
22	5261L020	下切刀固定座	Lower cutter fixed base	1
23	5261L060	下切刀	Lower cutter	1
24	5261L100	下刀座	Lower knife holder	1
25	5261L150	切刀固定座铜套	Cutter fixed copper sleeve	1
26	52024200	油棉	Oil wick	0.2M
27	5261L110	切刀主轴	Cutter spindle	1
28	00804030	内紧定螺钉M4X3	Inner set screw M4x3	1
29	52093911	一字平头螺钉M3.5x10 (发黑)	Flat head slotted screw M3.5x10 (blackened)	1
30	01205121	内六角螺栓M5X12 (黑色)	Hex socket bolt M5x12 (black)	1
31	5261L180	切刀固定座护盖垫片	Cutter fixed base guard washer	1
32	5261L190	切刀固定座护盖	Cutter fixed base guard cover	1
33	52093926	一字平头螺钉M3X6 (发黑)	Flat head slotted screw M3x6 (blackened)	5
34	52094410	十字盘头螺钉M4X10 (发黑)	Cross pan head screw M4x10 (blackened)	1
35	52007220	平垫圈	Flat washer	1
36	5261L330	吸布屑管	Fabric scrap suction tube	1
37	5261L430	卡箍	Clamp	1
38	5261L320	吸布屑管	Fabric scrap suction tube	1
39	52094900	一字球面圆柱头螺钉M4X10 (发黑)	Oval head slotted screw M4x10 (blackened)	1
40	5261L030	上切刀固定座	Upper cutter fixed base	1
41	52092935	一字平头螺钉M3.5X5(发黑)	Flat head slotted screw M3.5x5 (blackened)	1
42	5261L050	切屑接收器	Chip receiver	1
43	5261Q980	圆柱销Φ2x5	Dowel pin Φ2x5	1
44	5261L040	上切刀	Upper cutter	1
45	52094955	一字平头螺钉M4X5.5 (发黑)	Flat head slotted screw M4x5.5 (blackened)	1
46	01206121	内六角螺栓 (黑色) M6X12	Hex socket bolt (black) M6x12	2

## 2. 左刀部件 (2) /Left-Knife Assembly (2)

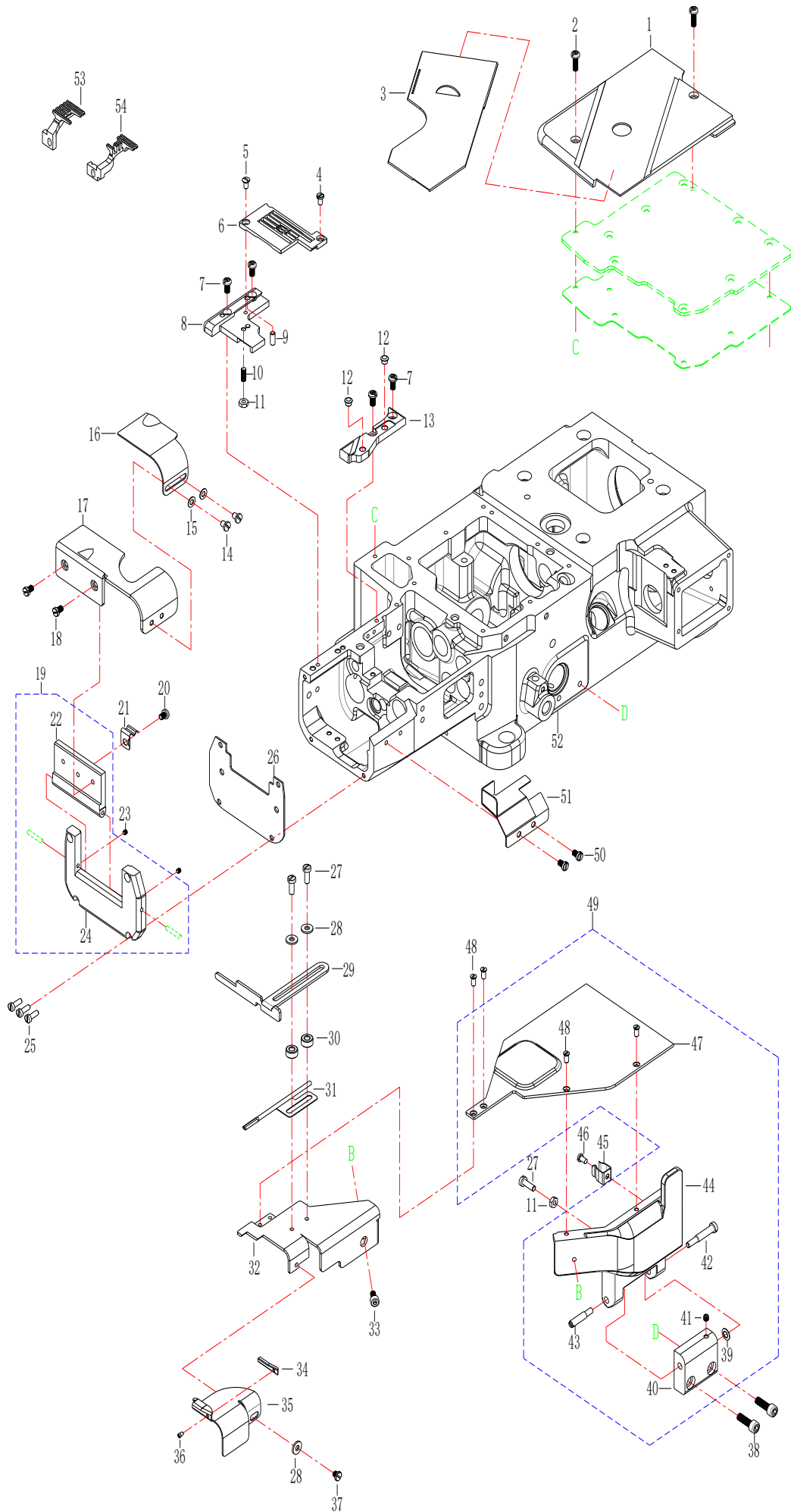

## 2. 左刀部件 (2) /Left-Knife Assembly (2)

NO	零部件号	零部件名称	NAME OF PARTS	数量 (Number)
1	5261L370	缝制平台	Sewing platform	1
2	52094412	十字盘头螺钉M4X12 (发黑)	Cross pan head screw M4x12 (blackened)	2
3	5261L380	滑盖	Sliding cover	1
4	52092916	一字平头螺钉M3.5x6 (发黑)	Flat head slotted screw M3.5x6 (blackened)	1
5	5261Q860	一字半沉头螺钉SM9/64 (40)	Flat countersunk head screw SM9/64 (40)	1
6	XXXXXXXX	针板	Needle plate	1
7	52094408	十字盘头螺钉M4X8 (发黑)	Cross pan head screw M4x8 (blackened)	4
8	5261L310	针板座	Needle plate holder	1
9	5261Q870	圆柱销Φ4x10	Dowel pin Φ4x10	1
10	00804100	内紧定螺钉M4X10	Inner set screw M4x10	1
11	00404031	螺母黑色M4	Nut (black) M4	2
12	5261L410	减震垫	Vibration damping pad	2
13	5261L390	辅助盖板	Auxiliary cover plate	1
14	52094945	一字平头螺钉M4X5 (发黑)	Flat head slotted screw M4x5 (blackened)	2
15	52007220	平垫圈	Flat washer	2
16	5261L270	圆筒顶盖挡板	Cylinder top cover baffle	1
17	5261L260	圆筒顶盖	Cylinder top cover	1
18	52094955	一字平头螺钉M4X5.5 (发黑)	Flat head slotted screw M4x5.5 (blackened)	2
19	5261LZ030	下侧盖组	Lower side cover assembly	1
20	52094405	十字盘头螺钉M4X5 (发黑)	Cross pan head screw M4x5 (blackened)	1
21	5261Q460	夹簧	Clamp spring	1
22	5261L300	圆筒上侧盖	Cylinder upper side cover	1
23	52094103	内六角平端紧定螺钉M4X3 (发黑)	Hex socket flat point set screw M4x3 (blackened)	2
24	5261A050	下侧盖	Lower side cover	1
25	52092910	一字平头螺钉M3.5x10 (发黑)	Flat head slotted screw M3.5x10 (blackened)	3
26	5261A070	下侧盖垫片	Lower side cover gasket	1
27	52094932	一字球面圆柱头螺钉M4X12 (发黑)	Oval head slotted screw M4x12 (blackened)	3
28	5261Q910	平垫圈4	Flat washer 4	3
29	5261L240	右导布器	Right fabric guide	1
30	5261L250	垫圈	Washer	2
31	5261L230	气压式整平器	Pneumatic leveler	1
32	5261L200	导布器支架	Fabric guide bracket	1
33	02000018	内六角螺栓M4X8 (发黑)	Hex socket bolt M4x8 (blackened)	1
34	5261L220	导布器	Fabric guide	1
35	5261L210	左导布器	Left fabric guide	1
36	5261Q900	一字平头螺钉SM3-32 (56) (发黑)	Flat head slotted screw SM3-32 (56) (blackened)	1
37	02000060	螺钉M4×4	Screw M4x4	1
38	01205146	内六角螺栓M5X14 (材料定制)	Hex socket bolt M5x14 (custom material)	2
39	5261Q050	鞍形弹性垫圈5	Dome spring washer 5	1
40	5261A240	前盖底座	Front cover base	1
41	00804040	内紧定螺钉M4X4	Inner set screw M4x4	1
42	5261Q020	轴位螺钉	Shoulder screw	1
43	5261Q030	段螺钉	Segment screw	1
44	5261L350	前盖	Front cover	1
45	5261Q120	卡簧	Retaining ring	1
46	52092906	一字平头螺钉M3.5X6 (发黑)	Flat head slotted screw M3.5x6 (blackened)	1
47	5261L360	前盖盖板	Front cover plate	1
48	52092507	一字沉头螺钉M3.5x7.5 (发黑)	Countersunk head screw M3.5x7.5 (blackened)	4
49	5261LZ520	前盖组件	Front cover assembly	1
50	02000042	一字螺钉M4X6	Slotted screw M4x6	2
51	5261L400	防护板	Guard plate	1
52	5261L010	下座	Lower base	1
53	XXXXXXXX	主送齿	Main feed dog	1
54	XXXXXXXX	差送齿	Differential feed dog	1

### 3. 步进左刀装置/Stepper Left-Knife Unit

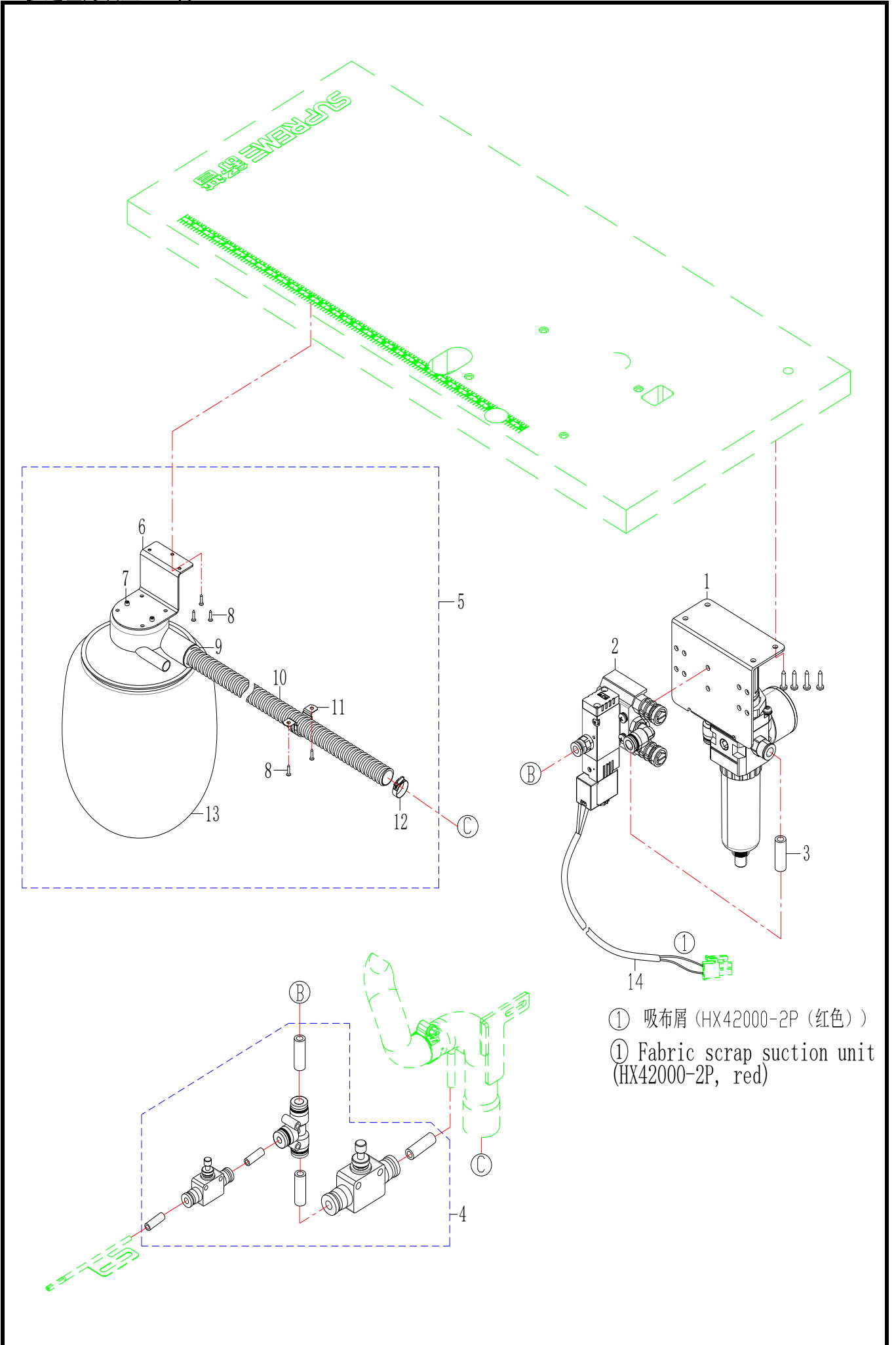

### 3. 步进左刀装置/Stepper Left-Knife Unit

NO	零部件号	零部件名称	NAME OF PARTS	数量 (Number)
1	52112400	调压过滤器 (自动款)	Pressure regulator filter (auto model)	1
2	52110240	一联电磁阀组件	Single solenoid valve assembly	1
3	13205590	空气管 φ8	Air tube φ8	0.37M
4	5261LZ020	一联电磁阀气管组	Single solenoid valve tube assembly	1
5	5261YZ090	气动集尘装置	Pneumatic dust collection device	1
6	52110033	Z型安装支架	Z-type mounting bracket	1
7	52097212	内六角螺栓M6X12X0.75 (发黑)	Hex socket bolt M6x12x0.75 (blackened)	2
8	52110038	自攻螺丝	Self-tapping screw	5
9	5261Y280	转接件	Adapter	1
10	5261Y281	螺旋管	Spiral hose	1
11	5261Y282	卡扣	Snap clip	1
12	5261Y283	卡箍	Clamp	1
13	52110034	集尘袋	Dust collection bag	1
14	52007560	一联线束	Single wiring harness	1

#### 4. 步进左刀吹风装置 (FTL/UTFA)/Stepper Left-Knife Air-Jet Unit (FTL/UTFA)

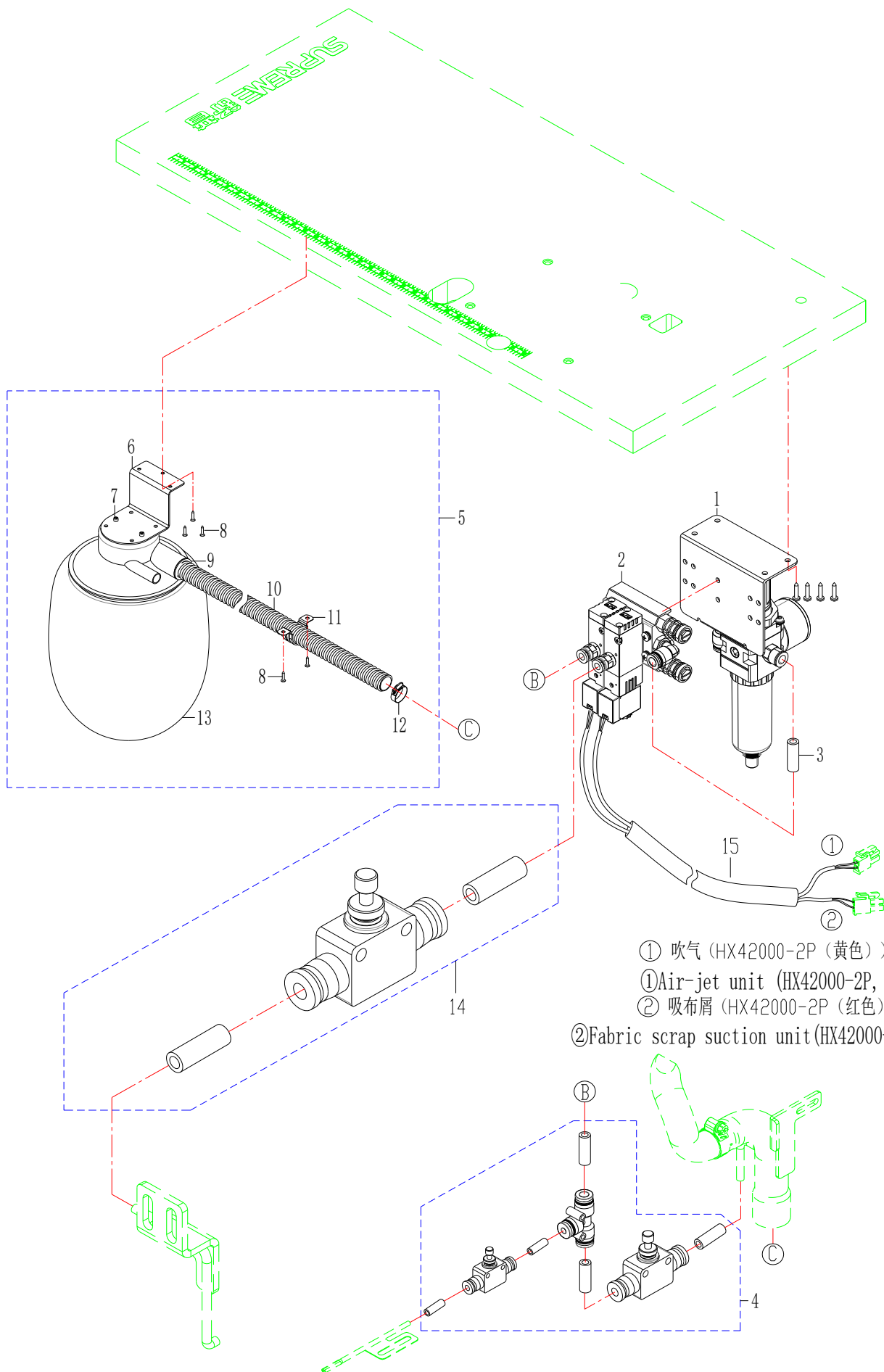

- ① 吹气 (HX42000-2P (黄色))
- ① Air-jet unit (HX42000-2P, yellow)
- ② 吸布屑 (HX42000-2P (红色))
- ② Fabric scrap suction unit (HX42000-2P, red)

4. 步进左刀吹风装置 (FTL/UTFA) / Stepper Left-Knife Air-Jet Unit (FTL/UTFA)

NO	零部件号	零部件名称	NAME OF PARTS	数量 (Number)
1	52112400	调压过滤器 (自动款)	Pressure regulator filter (auto model)	1
2	5261UZ110	二联电磁阀组件	Double solenoid valve assembly	1
3	13205590	空气管 φ8	Air tube φ8	0.37M
4	5261LZ020	一联电磁阀气管组	Single solenoid valve tube assembly	1
5	5261YZ090	气动集尘装置	Pneumatic dust collection device	1
6	52110033	Z型安装支架	Z-type mounting bracket	1
7	52097212	内六角螺栓M6X12X0.75 (发黑)	Hex socket bolt M6x12x0.75 (blackened)	2
8	52110038	自攻螺丝	Self-tapping screw	5
9	5261Y280	转接件	Adapter	1
10	5261Y281	螺旋管	Spiral hose	1
11	5261Y282	卡扣	Snap clip	1
12	5261Y283	卡箍	Clamp	1
13	52110034	集尘袋	Dust collection bag	1
14	5261LZ040	一联电磁阀气管组	Single solenoid valve tube assembly	1
15	52007563	二联线束	Double wiring harness	1

# 5. 气动左刀装置 (FTL/UTA) /Pneumatic Left-Knife Unit (FTL/UTA)

①+②+③+④+⑤+⑥+⑦= 1

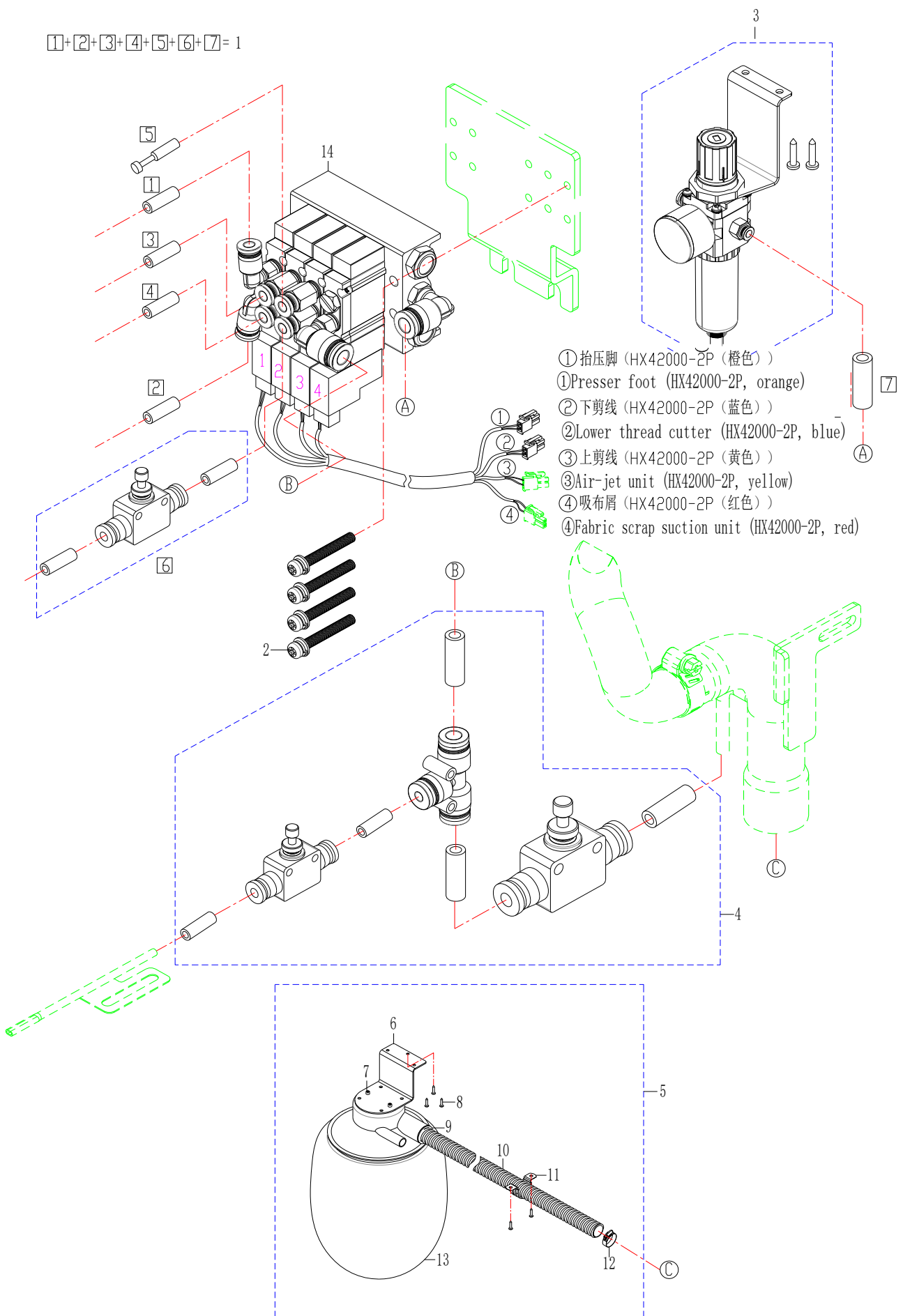

5. 气动左刀装置 (FTL/UTA) /Pneumatic Left-Knife Unit (FTL/UTA)

NO	零部件号	零部件名称	NAME OF PARTS	数量 (Number)
1	5261UZ101	吹气管组	Air-jet tube assembly	1
2	01504300	十字盘头带垫片螺钉M4X30DB	Cross pan head screw with washer M4x30DB	4
3	5261UZ080	调压过滤器	Pressure regulator filter	1
4	5261LZ020	一联电磁阀气管组	Single solenoid valve tube assembly	1
5	5261YZ090	气动集尘装置	Pneumatic dust collection device	1
6	52110033	Z型安装支架	Z-type mounting bracket	1
7	52097212	内六角螺栓M6X12X0.75 (发黑)	Hex socket bolt M6x12x0.75 (blackened)	2
8	52110038	自攻螺丝	Self-tapping screw	5
9	5261Y280	转接件	Adapter	1
10	5261Y281	螺旋管	Spiral hose	1
11	5261Y282	卡扣	Snap clip	1
12	5261Y283	卡箍	Clamp	1
13	52110034	集尘袋	Dust collection bag	1
14	5261UZ091	四联电磁阀组	Quad solenoid valve assembly	1

# 6. 气动左刀装置 (FTL/UTC) /Pneumatic Left-Knife Unit (FTL/UTC)

①+②+③+④+⑤+⑥+⑦= 1

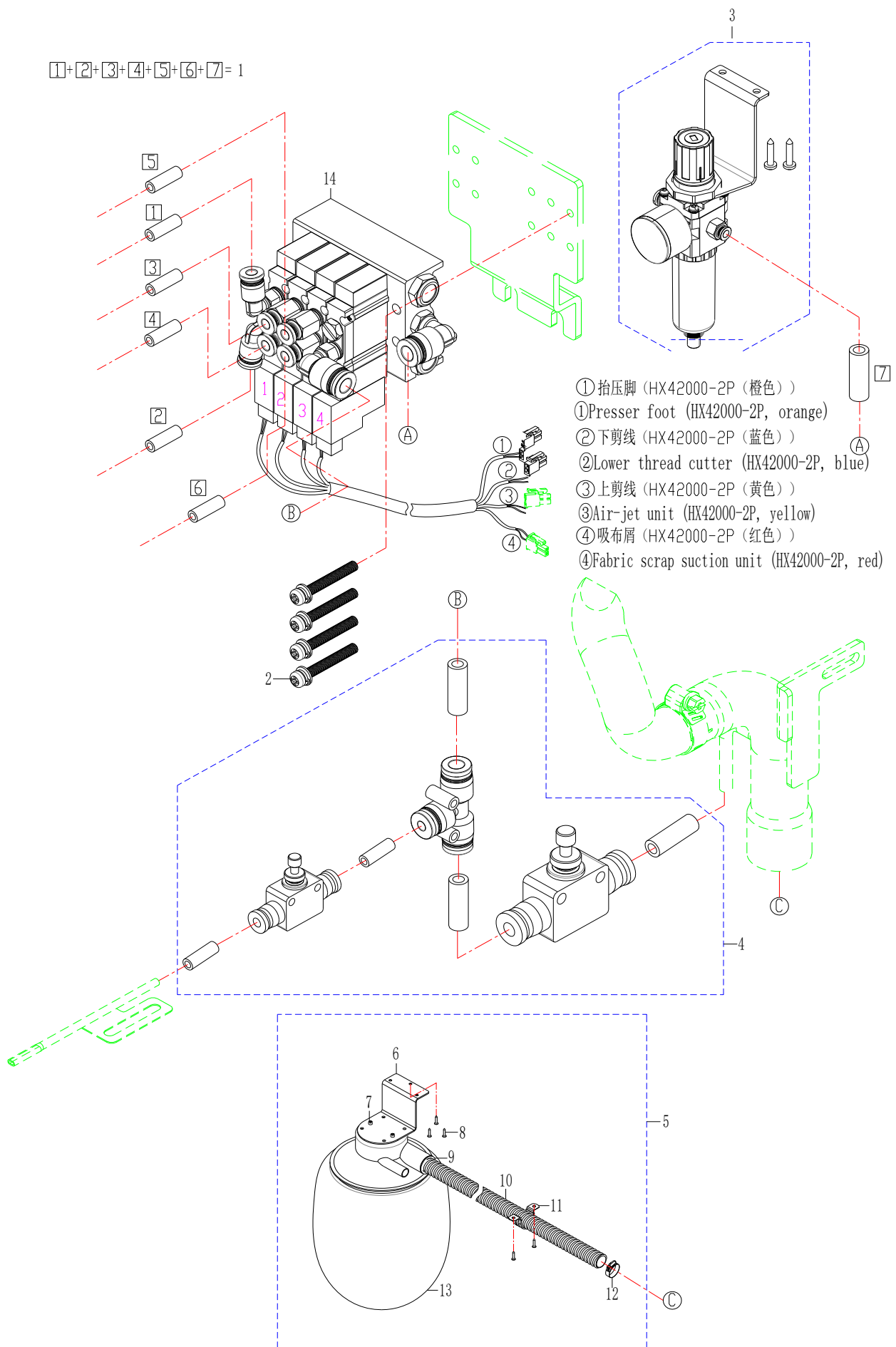

6. 气动左刀装置 (FTL/UTC) /Pneumatic Left-Knife Unit (FTL/UTC)

NO	零部件号	零部件名称	NAME OF PARTS	数量 (Number)
1	5261UZ100	上剪线气管组	Upper thread cutter tube assembly	1
2	01504300	十字盘头带垫片螺钉M4X30DB	Cross pan head screw with washer M4x30DB	4
3	5261UZ080	调压过滤器	Pressure regulator filter	1
4	5261LZ020	一联电磁阀气管组	Single solenoid valve tube assembly	1
5	5261YZ090	气动集尘装置	Pneumatic dust collection device	1
6	52110033	Z型安装支架	Z-type mounting bracket	1
7	52097212	内六角螺栓M6X12X0.75 (发黑)	Hex socket bolt M6x12x0.75 (blackened)	2
8	52110038	自攻螺丝	Self-tapping screw	5
9	5261Y280	转接件	Adapter	1
10	5261Y281	螺旋管	Spiral hose	1
11	5261Y282	卡扣	Snap clip	1
12	5261Y283	卡箍	Clamp	1
13	52110034	集尘袋	Dust collection bag	1
14	5261UZ091	四联电磁阀组	Quad solenoid valve assembly	1

7. 非自动剪线左刀装置/Non-Auto-Thread-Trimming Left-Knife Unit

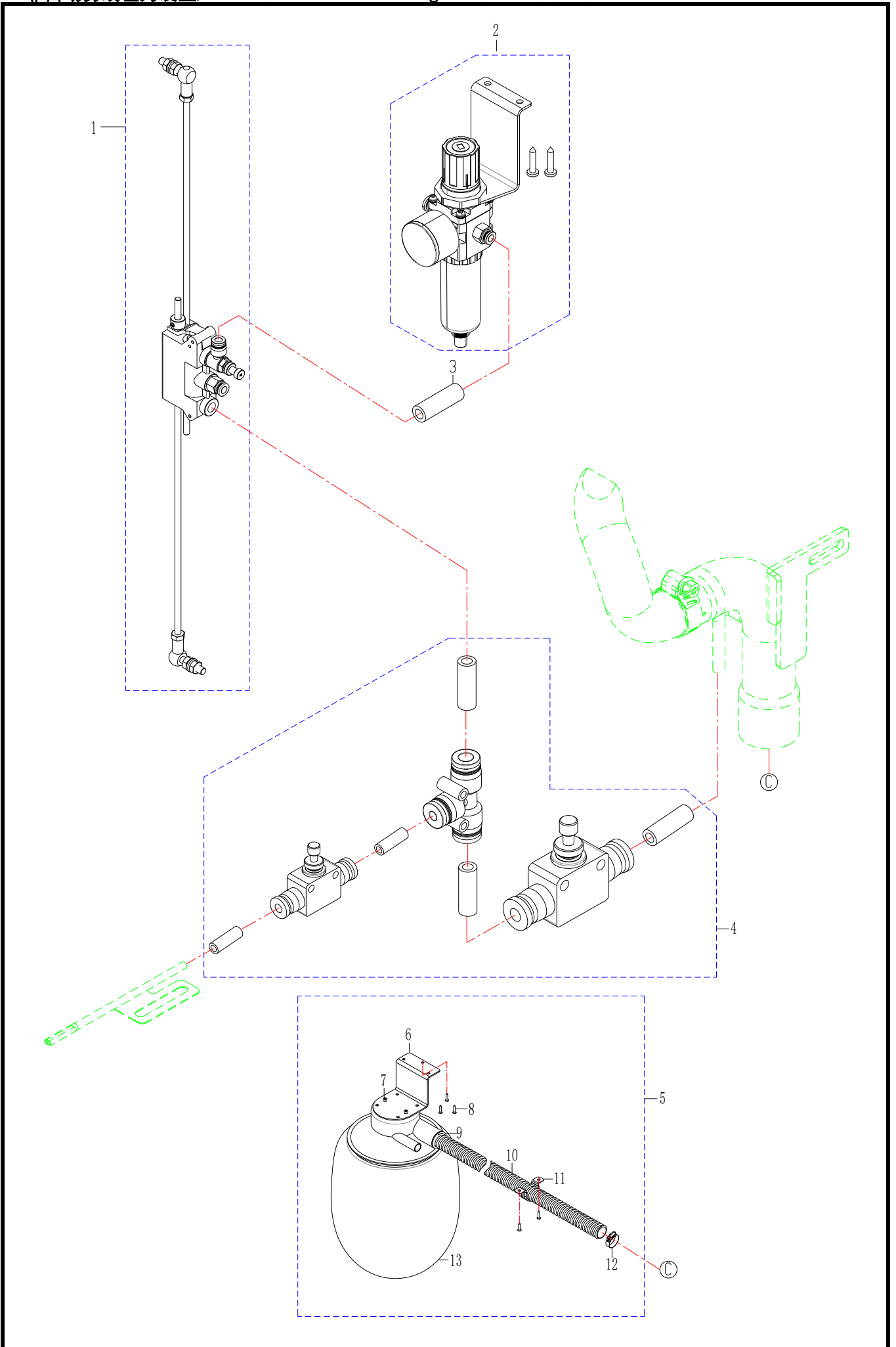

## 7. 非自动剪线左刀装置/Non-Auto-Thread-Trimming Left-Knife Unit

NO	零部件号	零部件名称	NAME OF PARTS	数量 (Number)
1	5261Y290	气动拉杆组件	Pneumatic rod assembly	1
2	5261UZ080	调压过滤器	Pressure regulator filter	1
3	10126690	气管	Air tube	0.4M
4	5261LZ020	一联电磁阀气管组	Single solenoid valve tube assembly	1
5	5261YZ090	气动集尘装置	Pneumatic dust collection device	1
6	52110033	Z型安装支架	Z-type mounting bracket	1
7	52097212	内六角螺栓M6X12X0.75 (发黑)	Hex socket bolt M6X12X0.75 (blackened)	2
8	52110038	自攻螺丝	Self-tapping screw	5
9	5261Y280	转接件	Adapter	1
10	5261Y281	螺旋管	Spiral hose	1
11	5261Y282	卡扣	Snap clip	1
12	5261Y283	卡箍	Clamp	1
13	52110034	集尘袋	Dust collection bag	1

